

Kyoto University

Research Activities

Vol.3 No.4 March 2014

Special Features:

Kyoto University's International Relations Endeavors



京都大学

Research Activities

Vol.3 No.4
March 2014

Contents

- MESSAGE FROM THE PRESIDENT
- 1 **A Proactive Approach to International Relations**
- INTRODUCTION
- 2 **Kyoto University: A Global Perspective**
- HISTORY
- 4 **The Legacy of Kinji Imanishi**
Kyoto University's Heritage of Fieldwork and Primatology
- AWARDS & HONORS
- 7 **International Recognition of Kyoto University's Research**
- GLOBAL NETWORK
- 10 **International Relations at Kyoto University**
- LARGE-SCALE PROJECTS
- 18 **Promotion of International Education and Research**
- CUTTING-EDGE EXPERIMENTAL EQUIPMENT
- 20 **Facilities for High Quality Research**
- FOSTERING THE NEXT GENERATION
- 22 **白眉 — The Hakubi Project**
A Unique Opportunity for Outstanding Young Talent
- FOSTERING THE NEXT GENERATION
- 24 **The John Mung Program**
Opportunities to Explore Global Frontiers
- RESEARCH FRONTIERS
- 26 **Cutting-Edge Research in Kyoto University**
- RESEARCH OUTPUT
- 30 **Kyoto University Merchandise?!**
Another Use for Research Results
- 32 AUTHOR INDEX
- 33 MAP AND ACCESS

Cover Photograph



Clock Tower with cherry blossoms



About
the Clock Tower

MESSAGE FROM THE PRESIDENT

A Proactive Approach to International Relations

Kyoto is a historic city with a thousand-year-old accumulation of art and culture, but it is not a city which clings stubbornly to tradition or dwells excessively on past glories. Kyoto has always been a city that has continued to cultivate a fresh and vibrant culture through maintaining a broad interaction with the world. As a vital element of that cultural heritage, the scholars of Kyoto University have, since the institution's foundation, continued to direct their efforts towards new fields of study and engage in research activities that span the globe. In this issue, we introduce one such researcher: the ecologist and anthropologist Kinji Imanishi, widely known as one of the founders of primatology in Japan. The spirit of such pioneers continues to permeate Kyoto University to this day.

In June 2013, Kyoto University finalized its new international strategy: The 2x by 2020 Initiative, and we began to accelerate our internationalization efforts throughout the university. Through this initiative, we seek not only to support the efforts of individual researchers, but to actively engage with the international community, concentrating on the strategy's three central pillars of research, education, and international service.

This issue of Research Activities focuses on Kyoto University's international relations endeavors. I hope that you will find it of interest, and that its pages will convey some of our passion and enthusiasm for this area of development.

March 2014



Hiroshi Matsumoto
President, Kyoto University



INTRODUCTION

Kyoto University: A Global Perspective

Kyoto University is the second oldest research university in Japan. As a truly international institution with numerous overseas facilities, it is dedicated to providing a free-thinking academic environment with a global perspective.

Overview: University Profile

Mission The mission of Kyoto University is to sustain and develop its historical commitment to academic freedom and to pursue harmonious coexistence within the human and ecological community on this planet.

Foundation Kyoto University was originally founded as Kyoto Imperial University on the June 18, 1897. It was the second imperial university to be established in Japan.

Students
(As of May 1, 2013)

Undergraduate students:	13,421
Master's course students:	4,846
Professional course students:	728
Doctoral course students:	3,682

Faculty and Staff
(As of May 1, 2013)

Faculty members:	3,406
Non-teaching staff members:	2,655

Facilities and Environment
(As of May 1, 2013)

Faculties:	10
Graduate Schools:	18
Research Institutes:	14
Intra-University Networks and Organizations:	6
Education and Research Centers:	21
Overseas Offices and Facilities:	50



KU Key Words

Freedom and Autonomy ◆

Kyoto University values **freedom and autonomy** in research that conforms to high ethical standards, and believes in promoting a disciplinarily diverse spectrum of research, while also pursuing an integrated, **multidisciplinary approach**.

Self-Reliance and Self-Respect ◆

The principles of **self-reliance** and **self-respect** are key elements in Kyoto University's academic approach. Guided by those concepts, students and researches are encouraged to be bold, independent, and creative in their study and research.

The Hakubi Project ◆

A unique program to foster outstanding young researchers, the Hakubi Project recruits **twenty international researchers per year** as associate and assistant professors, and gives them the valuable opportunity to devote themselves entirely to their research.

The John Mung Program ◆

A program to support **mid-** and **long-term** research by junior faculty members at leading academic institutions overseas. Since 2013, the program is also open to students and non-teaching staff members.

2× by 2020 ◆

2× by 2020 (Double by Twenty-Two) is the slogan of Kyoto University's new international strategy, by means of which the university aims to double its international indices in research, education, and international service by the year 2020.



By the Numbers

JPY 202,124 million	FY2012 revenues
16%	Percent of funding from external sources in the revenues
JPY 158,526 million	FY2012 expenses
44%	Percent of instruction and research costs, the largest portion of the expenses
JPY 220 million	Revenue from patent licenses (FY2012)
1,733	International students (As of May 1, 2013)
779	Students studying abroad (FY2012)
240	International faculty members (as of May 1, 2012)
2,950	International researchers hosted Annually (FY 2011)
281,948	Academic paper citations (total from 2007-2011. From InCites™, Thomson Reuters)
8	Number of Nobel laureates that have taught on campus

More about Kyoto University

International Accolades ◆

In addition to eight **Nobel Prizes**, Kyoto University researchers have garnered two **Fields Medals**, one **Gauss Prize**, four **Lasker Awards**, two **Japan Prizes**, and four **Kyoto Prizes**.

Academic Exchange Agreements ◆

Kyoto University has academic exchange agreements with ninety-three universities, four university associations, and one national academy.

Kyoto: The Academic Center of Japan ◆

Kyoto has a long history as a university town. In the Heian period (794-1185), when Kyoto was the nation's capital, it was the location of an imperial institution of higher education called the *Daigaku-ryō*. Comparable to today's national universities, staff members at the *Daigaku-ryō* held posts equivalent to the current positions of university president, teaching staff, and administrative staff, and departments within the institution were also the equivalent of current university faculties. At present, Kyoto embraces thirty-eight institutions of higher education, making it one of the most concentrated academic centers in Japan.



The Legacy of Kinji Imanishi

Kyoto University's Heritage of Fieldwork and Primatology

ANTHROPOLOGY and primatology fieldwork at Kyoto University is rooted in the tradition of the Academic Alpine Club of Kyoto (AACK), which was established by Kinji Imanishi and his colleagues in 1931. The AACK's activities centered on climbing uncharted mountains, and the group made several expeditions into unknown parts of Asia under their motto of "ascent of virgin peaks." Their expeditions were always motivated by academic interests, with the members comprising an interdisciplinary research team of anthropologists, zoologists, botanists, geologists, and other specialists.

After World War II, the club splintered into several groups focusing on distinct academic fields, but the resulting groups continued to interact with each other. Imanishi was based in Kyoto University's Department of Zoology, and his initial field studies focused on feral



Imanishi at the top of Mt. Meru in Tanzania. It was his first research trip to Africa. (Photo from Itani Jun'ichiro Archives at PRI, Kyoto University)



Kinji IMANISHI (1902-1992)

Kinji Imanishi was an entomologist, ecologist, anthropologist, founder of Japanese primatology, and an accomplished mountaineer, who had great popularity as an explorer among the Japanese public (from the WEB site "The Kinji Imanishi Digital Archive at Alberta University," <http://tomcat.sunsite.ualberta.ca/Imanishi/>). He was also the founder of Kyoto University's Primate Research Institute.



From right, Itani, Imanishi, Kawamura. Upper, Tokuda, at Toi Cape, which was known for wild horses. (Photo from Itani Jun'ichiro Archives at PRI, Kyoto University)

horses and Japanese macaques. He believed that understanding animal societies would aid in tracing the evolution of human society. Imanishi developed a new definition of society from the viewpoint of combining both the organism and its habitat, and he applied it to all living things. He devised a guide for field studies which entailed adopting the methods of comparative sociology, basing work on individual identifications, and recording social interactions through prolonged and continuous observations. This later came to known as the Japanese method.

After the retirement of Imanishi in 1965, Junichiro Itani led the university's studies in primatology and ecological anthropology. Field studies were conducted mainly on the great apes (bonobos, chimpanzees, and gorillas), hunter-gatherers, pastoralists, and slash-and-

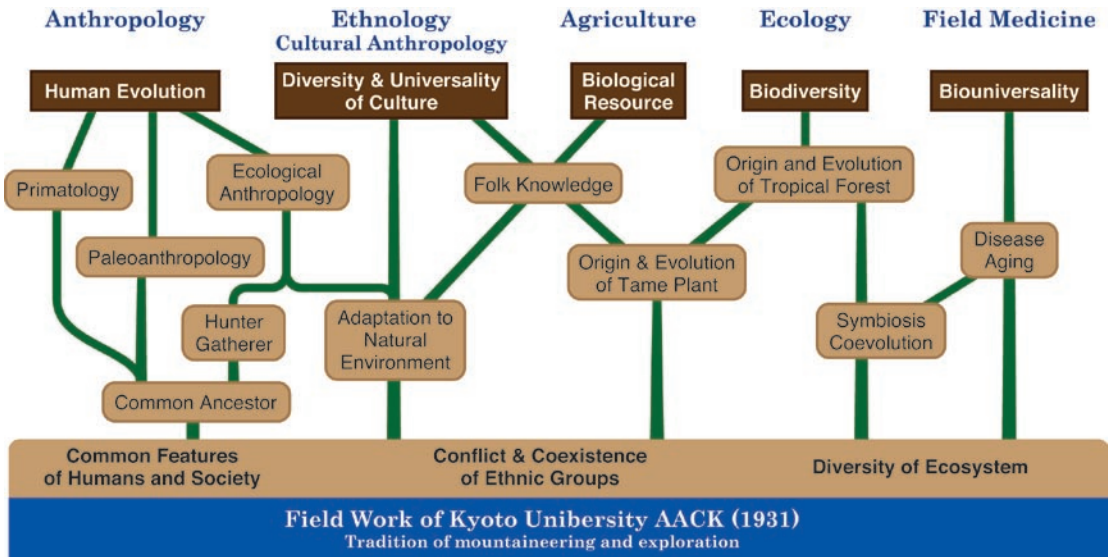

burn farmers in Africa. Graduate students were directed to collect data by following their intuition and curiosity, especially firsthand data on phenomena that had previously gone unnoted. The phrase “let the data speak” became the motto of their research. New findings on the behavior of apes in their natural habitats, such as food sharing, hunting, tool using, face-to-face interactions, homosexual interactions, displays and greetings, have enabled scholars to present new arguments on the social features and social

evolution of the great apes. These findings are analyzed in comparison with human society in order to elucidate its evolution. Itani challenged the concept of the “natural man” asserted by Jean-Jacques Rousseau, who described a process from human equality at the primitive state to inequality at the civil state. Itani proposed a possible evolutionary pathway from the equipotent state of an elemental society to the equality of a monogamous society, and compared the inequality of group-living non-human primates



Imanishi (center) and Itani (left) in search of wild gorillas in Uganda on March 6th 1958. (Photo from Itani Jun'ichiro Archives at PRI, Kyoto University)



Early Primates study group at Japan Monkey Centre in Inuyama. From right, Sonohara, Imanishi, Itani, and Kawai. (Photo from Itani Jun'ichiro Archives at PRI, Kyoto University)

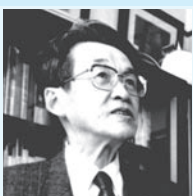

Junichiro Itani (1926-2001)

Junichiro Itani was also a founder of the discipline of Japanese primatology. Objects of his research were from Japanese wild monkeys to chimpanzees and gorillas in Africa. He was renowned as a first anthropologist who found that chimpanzees and gorillas had distinct social comparable to those of humans. For this achievement, he was awarded the Thomas Huxley Memorial Medal from Royal Anthropological Institute of Great Britain and Ireland, in 1984.



Face-to-face communication of gorillas



Student field work at Arashiyama Monkey Park



Meat sharing among chimpanzees



Japanese macaque and deer



Researchers at the time gathered in front of the entrance of Japan Monkey Centre, completed in 1967. (Photo from Itani Jun'ichiro Archives at PRI, Kyoto University)

to the conditional equality of human society. The origin of human family and sociality is still a major focus in primatology and anthropology. The conservation of endangered species, including great apes, and the preservation of indigenous cultures have also become important tasks. With the rapid advancement of globalization, field studies on human and non-human primates are having an increased impact on policy making and bringing harmony to human communities.

Author: **Dr. Juichi Yamagiwa**

Professor, Graduate School of Science

WEB jinrui.zool.kyoto-u.ac.jp/others/WelcomeE.html



Itani Junichiro Archives

Junichiro Itani (1926-2001), a student of Kinji Imanishi, was a founding member of the Japanese school of primatology. "Itani Jun'ichiro Archives" stores numerous pictures of his research, field notes, and many other handwritten documents.

WEB www.pri.kyoto-u.ac.jp/archives/index.html



AWARDS & HONORS

International Recognition of Kyoto University's Research

INTERVIEW

Kiyoshi Kobayashi was Awarded in November 2013

by the Vietnam Ministry of Education and Training.

Prof. Kiyoshi Kobayashi was awarded the Medal for the Cause of Education by the Vietnam Ministry of Education and Training (MOET) on November 8, 2013. In commemoration of the 40th anniversary of the establishment of diplomatic relations between Vietnam and Japan, the medals were awarded to four Japanese professors who have made great contributions to the development of education and training in Vietnam. Prof. Kobayashi has contributed to the development of Vietnamese human resources through his research and education activities on infrastructure asset management^{*1}.



— *What made you engage in the education activities in Vietnam?*

Kobayashi: I started the activities after I visited Vietnam for the post-project evaluation of JICA's ODA Loan project in 2004. In the summer of that year, the asset management methodology course I developed commenced at the University of Transport and Communications (UTC). In the first year, I ran a small class at my own expense without any funding from the government or the university. From following next year, however, I was involved in the course as an invited organizer. I was invited by the course's two instructors, who were the most earnest students in

my course. Awareness of the course has spread by word-of-mouth, and the number of students has been increasing every year. There are now over 300 students in total. Approximately one third of the students are academic scholars, one third are government officials, and one third are business people. Last year, the asset management system I developed was implemented on a trial basis in Northern Vietnam, and the students in the course played a central role in the development of the Vietnam's own system.

— *At the 60th Annual North American Meeting of the Regional Science Association International (RSAI), you also received a Award^{*2}. What is your philosophy of research that forms the basis for such outstanding achievements?*

Kobayashi: I First, I try to do what nobody else is doing. Or alternatively, I look at things which are considered to have been completed, and try to find aspects which have not actually been accomplished or achieved. I also consistently focus on "what is the point of this." These three elements form my philosophy.





— *What is your future vision for your research?*

Kobayashi: I don't have a specific plan that I can say "this is my future vision." However, I would like to go back to the concept of civil engineering which is my original specialty, and re-examine the many things that I wanted to do when I began my life as a researcher.

Prof. Kobayashi is the program leader of the Global Business Leader Program (GBL). The program seeks to create networks of government authorities and top business schools in major Asian countries, and conduct empirical studies in an effort to propose business models which can advance economic and social growth in Japan and Asia. The Asian countries participating in the program are Thailand, India, Vietnam, Indonesia, China, the Philippines and Malaysia.

WEB asia-gsm-ku.com/gbl/index.php/concept

*1 Preventive maintenance and repair help ensure the long life expectancy of infrastructure, and save maintenance costs in the long run. If preventive maintenance and repair are postponed, future generations will have to bear a huge burden in maintenance costs. To avoid such situations, the concept of asset management to position infrastructure as public assets, and implement systematic and precise preventive maintenance and repair was developed.

*2 the 2013 RSAI Fellow Award: An Award recognizes scholars who have demonstrated excellence in regional science, enduring leadership, and who have made an outstanding contribution to the association.

Dr. Kiyoshi Kobayashi

*Professor of Graduate School of Management
Research Topics: planning-management theory,
asset management, infrastructure economics*

WEB kyouindb.iimc.kyoto-u.ac.jp/e/hr7IU



TOPIC **The Tachibana Award**



Praise outstanding young female students and scientists at KU.

On March 3, on a sunny and warm day, the Tachibana Award Ceremony was held at Inamori Hall on the Yoshida Campus. At the ceremony, recipients of the Tachibana Award and the Encouragement Award were announced. Each recipient was honored with the award certificate and plaque from Dr. Matumoto, the President of Kyoto University, and an extra prize, from Mr. Yasuhara, the President of Wacoal corporations. The recipients of the Tachibana Award, Ms. Katayama and Dr. Wang also gave the presentations on their research.

The Tachibana Award was established in 2008 to acknowledge the achievements of outstanding young female students and scientists in the fields of humanities, social sciences, and natural sciences at Kyoto University. This year, 2013, twelve students and seventeen researchers were nominated and winners were as follows.

Tachibana Award Recipients 2013

- ◆ Student Division: **Yumiko Katayama**
Ph.D. Candidate, Graduate School of Human and Environmental Studies
"Material design of rare earth ion doped wavelength converters and elucidation of luminescence mechanisms for green photonics"
- ◆ Scientist Division: **Wang Liulan**
Associate Professor, Hakubi Center
"Chinese Diaspora in Asia and the Search for a New Paradigm of Multi-Diversified Co-existence"



Honorable Mention Award Recipients 2013

- ◆ Student Division: **Yuko Okumura**
Ph.D. Candidate, Graduate School of Letters
"The Elucidation of Social Learning Mechanism in Early Infancy"
- ◆ Scientist Division: **Shoko Sakai**
Associate Professor, Center for Ecological Research
"Plant reproductive ecology"



HONORS

Award Winning Researchers

The following is a list of just some of the Kyoto University researchers who have received international awards — a testimony to the university's intellectually fertile environment and culture of academic freedom.

Nobel Prize *in Physics*

Hideki Yukawa (1949), **Sin-Itiro Tomonaga** (1965),
Makoto Kobayashi (2008), **Toshihide Maskawa** (2008)

in Chemistry

Kenichi Fukui (1981), **Ryoji Noyori** (2001)

in Physiology or Medicine

Susumu Tonegawa (1987), **Shinya Yamanaka** (2012)

Fields Medal **Heisuke Hironaka** (1970), **Shigefumi Mori** (1990)

Gauss Prize **Kiyosi Itō** (2006)

Lasker Award **Susumu Tonegawa** (1987), **Yasutomi Nishizuka** (1989),
Yoshio Masui (1998), **Shinya Yamanaka** (2009)

Japan Prize **Makoto Nagao** (2005), **Masatoshi Takeichi** (2005)

*Photos provided by the Japan Prize Foundation

Kyoto Prize **Chushiro Hayashi** (1995), **Kiyosi Itō** (1998),
Shinya Yamanaka (2010), **Masatoshi Nei** (2013)

*Photos provided by the Inamori Foundation

- Die Schaudinn-Hoffmann-Plakette** ◆ **Shin-ichi Matsumoto** (1965)
Huxley Memorial Medal ◆ **Itani Junichiro** (1984)
Order of the White Elephant - 3rd Class ◆ **Yoneo Ishii** (1987)
Ross G. Harrison Prize ◆ **Tokindo Okada** (1989)
Salem Prize ◆ **Shishikura Mitsuhiro** (1992)
Robert Koch Prize ◆ **Shigekazu Nagata** (1995),
Shinya Yamanaka (2008),
Tasuku Honjo (2012)
The Keio Medical Science Prize ◆ **Nakanishi Shigetada** (1996),
Masatoshi Takeichi (2001),
Koichi Tanaka (2002),
Yoshinori Fujiyoshi (2005),
Shimon Sakaguchi (2008),
Kenji Kangawa (2009)
Frank Nelson Cole Prize ◆ **Hiraku Nakazima** (2003)
John Dawson Prize ◆ **Tetsuya Sato** (2005)
Yuri Gagarin Medal ◆ **Hiroshi Matsumoto** (2006)
Booker Gold Medal ◆ **Hiroshi Matsumoto** (2008)
The Ulysses Medal ◆ **Shuh Narumiya** (2008)
L.S.B. Leakey Prize ◆ **Toshisada Nishida** (2008)
**Prix du Rayonnement de la langue
et de la littérature françaises** ◆ **Kazuyoshi Yoshikawa** (2010)
de Gennes Prize ◆ **Susumu Kitagawa** (2013)



S. Tomonaga



H. Yukawa



H. Hironaka



K. Fukui



S. Tonegawa



Y. Nishizuka



S. Mori



C. Hayashi *



Y. Masui



R. Noyori



M. Nagao *



M. Takeichi *



K. Ito *



M. Kobayashi



T. Maskawa



S. Yamanaka *



M. Nei *

International Relations at Kyoto University

International cooperation and exchange is an indispensable component of Kyoto University's operations as a world-class higher education and research institution seeking to make a significant contribution to a stable and harmonious global society.

NEWS TOPICS

The 2x by 2020 Initiative

Kyoto University's International Strategy.

In June 2013, Kyoto University formulated a new international strategy in order to further develop the university as an institution of higher learning and a producer of world-class knowledge. Based on our mission statement, the strategy's driving force can be found in the academic tradition, creativity, and rich accumulation of culture for which the university is internationally renowned. Its aims are established around three central pillars of research, education, and international service.

The slogan of the strategy is "2x by 2020" (double by twenty-twenty), as it aims to double the university's performance in key international indices by the year 2020. It delineates specific measures and numerical targets to achieve its goals, such as an increase in the number of international academic exchange agreements from the current 93 to 200, and an increase of the number of international researchers at the university from the current 2,950 to 6,000.

The strategy also includes a specific target for the holding of international symposia, setting a goal to host approximately five international symposia per year in order to enhance the university's international presence, share our academic achievements with the international community, and promote international collaborative research. A brochure has been produced that provides full details of the strategy.

Contact:

Phone: +81-75-753-2207

e-mail: renkei@www.adm.kyoto-u.ac.jp

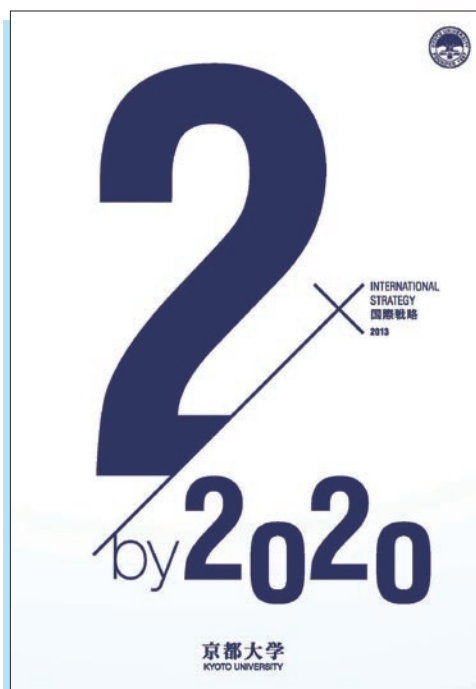

The brochure may be downloaded from the following website.

WEB

www.kyoto-u.ac.jp/ja/issue/international_strategy/index.htm



INTERNATIONAL PARTNERSHIPS

Academic Exchange Agreements with 113 Universities and Institutions



To date (January 10, 2014), Kyoto University has concluded academic exchange agreements with 113 universities and institutions (including four university associations and two research institutes). In the period from April 2013 to the present, the university concluded fifteen academic exchange agreements, including the renewal of an existing agreement with the University Catholique de Louvain. At present, forty-three agreements with European institutes (including NIS countries) and thirty-seven agreements with Asian institutes account for seventy percent of the 113 agreements concluded so far, indicating a particularly active involvement with institutions in Asia and Europe.

The fifteen academic exchange agreements concluded in the period from 2013 to the present are as follows:

- ◆ Saint-Petersburg State University
- ◆ The National University of Ukraine “Kyiv Polytechnic Institute”
- ◆ University of Cologne
- ◆ University Catholique de Louvain
- ◆ University of Glasgow
- ◆ Royal University of Bhutan
- ◆ University of Conakry
- ◆ Bogor Agricultural University
- ◆ Centre national de la recherche scientifique
- ◆ Mandalay Technological University
- ◆ Yangon Technological University
- ◆ University of Groningen
- ◆ Nanyang Technological University
- ◆ Jagiellonian University
- ◆ University of Zurich



SYMPOSIA & WORKSHOPS

Swiss-Kyoto Symposium, November 21-22



President Hiroshi Matsumoto and President Ralph Eichler (ETHZ)
(Photographs by Heidi Hostettler)

The Swiss-Kyoto Symposium was held at the Swiss Federal Institute of Technology Zurich on November 21-22, 2013. The event was held in cooperation between Kyoto University, the Swiss Federal Institute of Technology in Zurich (ETHZ), the University of Zurich (UZH), and École Polytechnique Fédérale de Lausanne (EPFL) in advance of next year's 150th anniversary of diplomatic relations between Switzerland and Japan.



Plenary wrap-up session
(Photograph by Heidi Hostettler)

Over 350 members from the participating institutions gathered over the two-day period of the symposium, with the aim of raising the international presence of the institutions, widely communicating research achievements, and promoting international cooperative research. The symposium comprised sixteen parallel academic sessions, which were held at various locations on the campuses of the Swiss universities, and also included the signing ceremony for a memorandum for academic cooperation and exchange between Kyoto University and UZH.

In addition to researchers from the four universities, many delegates from various Swiss organizations and institutions also participated in the symposium's academic sessions, engaging in enthusiastic discussions on future research collaboration (see below for a full list of session topics).

Plans are currently being made to follow up on the success of the event with a second symposium, which will be held at Kyoto University in cooperation with the three Swiss institutions.

Parallel Academic Sessions:

- ◆ Molecular and Cellular Basis of Development, Tissue Repair and Disease
- ◆ Magnetic Resonance
- ◆ Condensed Matter Physics
- ◆ Nanoelectronics and Nanophotonics
- ◆ Organic Chemistry and Materials Chemistry
- ◆ Product Development and Manufacturing
- ◆ Advanced Nano-/Biotechnology
- ◆ Energy
- ◆ Astrophysics
- ◆ AI and Robotics
- ◆ Natural Hazards and Disaster Prevention Research
- ◆ Virtual Ape
- ◆ Plant and Environment
- ◆ Finance and Risk
- ◆ Existentialismus heute
- ◆ Materials for Energy, Environment and Life



"Virtual Ape" session



"Plant and Environment" session



"Existentialismus heute" session



"Materials for Energy, Environment and Life" session

SYMPOSIA & WORKSHOPS

The 2nd Kyoto-Bristol Symposium, January 9-10, 2014



Sixty-two delegates from the University of Bristol, including the institution's vice-chancellor, Prof. Sir Eric Thomas, and several senior executives traveled to Kyoto University to attend the 2nd Kyoto-Bristol Symposium on January 9-10, 2014. Seeking to build on the success of the 1st Kyoto-Bristol Symposium, which was held last year at the University of Bristol,

the symposium is expected to initiate further cross-institutional activities. In total, approximately 240 participants attended the event.

The symposium's keynote speeches were delivered by Dr. Jeremy O'Brien, professor and director of the Centre for Quantum Photonics of Bristol University and Dr. Shinya Yamanaka, professor and director of Kyoto University's Center for iPS Cell Research and Application (CiRA). The proceedings also included the awarding of an honorary degree from the University of Bristol to President Hiroshi Matsumoto of Kyoto University.

Building on the foundations of the first symposium, the second edition added several new fields of research, including physical chemistry, nuclear materials, nano-photonics, plant sciences, and neuroscience. Parallel academic sessions (full list of session topics below) were held at various venues in the afternoon of January 9 and throughout the whole day of January 10, giving researchers from the two institutions an opportunity to explore new possibilities for research collaboration, as well as the further development of existing ties.

Parallel Academic Sessions:

Physical Chemistry and Materials Chemistry ♦ Nano-Science ♦ Nuclear Materials ♦ Robotics and Human Machine Interaction ♦ Intimacy and the Public Sphere ♦ Political Transformation in Southeast Asia ♦ Economic Theory ♦ Philosophy/Logic, English Literature, Colonialism ♦ Natural Hazards and Risks ♦ Nano-Photonics ♦ Plant Sciences ♦ Neuroscience ♦ Technology Transfer and Innovation

WEB www.kyoto-u.ac.jp/en/news_data/h/h1/news7/2013_1/140110_2.htm



President Matsumoto receives his honorary degree from Vice-Chancellor Sir Eric Thomas

SYMPOSIA & WORKSHOPS

The National Taiwan University and Kyoto University Symposium 2013



The National Taiwan University and Kyoto University Symposium 2013 was held at National Taiwan University (NTU) on December 19-20, 2013. Over 750 members from both universities gathered over the two-day period of the symposium with the aim of raising the international presence of the institutions, widely communicating research achievements, and promoting international cooperative research.



In his opening address, President Matsumoto spoke of his anticipation for the deepening of ties between NTU and KU, which have a long historical relationship, and of the research advancements that would come through the opportunities for networking between researchers provided by the symposium. A signing ceremony was also held for the conclusion of memorandum for student exchange between NTU and KU.

The topics of the academic sessions included such diverse fields as science and technology,

chemistry and material science, agriculture, biology, medicine, humanities, the social sciences, museums, and industry-academia cooperation. Many researchers and students from NTU participated in the sessions, engaging in the enthusiastic discussions on future research collaboration. Plans are currently being made for the next edition of the symposium, to be held at Kyoto University in September 2014.

WEB taiwan-kyoto2013.weebly.com/



SYMPOSIA & WORKSHOPS

The 3rd International Symposium on East Asian Vertebrate Species Diversity

For the Kyoto University Museum, a leading center for specimen-based research, the formation of borderless network in Asia is important for understanding the biodiversity of terrestrial vertebrates such as mammals, reptiles, and amphibians. Kyoto University has led this area research in Asia for over thirty years. Fostering young talent and competent field researchers who can collect data and specimens in Asian countries is also important in order to maintain a sustainable Asian network.



Dr. Motokawa gave a special lecture



Memorial Auditorium and Museum of Medicine



The Former Auditorium for Anatomy of the Kyoto University Graduate School of Medicine was established in 1902, and its single-story wooden building (with *sangawarabuki* hip-roof) has been designated by the university as a historical building. A completion ceremony and celebration was held on February 11, 2014 to commemorate the renewal of the former auditorium as the Memorial Auditorium and Museum of Medicine following renovation to strengthen its earthquake-resistance and other functions.

The stately Memorial Auditorium will be used as venue for a wide variety of lectures, events, and public programs, and the Museum of Medicine will exhibit to visitors from Japan and abroad a selection



This symposium is based on the activities of the 3-year JSPS AA Science Platform Program “Research Platform for East Asian Vertebrate Species Diversity and Formation of a Specimen Network,” a project which is operated in collaboration between the Kyoto University Museum and counterpart institutions in China, Korea, and Vietnam, and which involves 137 researchers from twenty-six organizations in five countries. Following the 1st symposium at Guangzhou University, China (2011) and the 2nd at Kyoto University (2012), this 3rd symposium was held at the Vietnam Academy of Science and Technology at Hanoi in Vietnam. The symposium lasted for two days, and eighty-eight researchers from eight Asian countries participated. The symposium aimed to provide a platform for the exchange of information about recent research activities, strengthen researcher networks, and develop young researchers.

Sixty-nine oral and poster presentations were given during the symposium. Most of the oral presentations were given by young researchers, including graduate students from Japan, Korea, China, Vietnam, Cambodia, the Philippines, and Russia, and many young people were also given the opportunity to chair the sessions. The symposium participants passionately engaged in discussions to promote the borderless, comprehensive understanding and conservation of Asian biodiversity. For the past three years the Kyoto University Museum has played a major role in establishing an Asian network for researchers and specimens, and looks forward to continuing to serve the international academic community by working to further strengthen the research network in Asia, and contributing to the development of young researchers in cooperation with its partners.



Poster presentation session



The six winners of the Young Researchers Best Presentation Award

Author: **Dr. Masaharu Motokawa**

Associate Professor, The Kyoto University Museum

WEB www.museum.kyoto-u.ac.jp/aa/index_en.html

of historical materials illustrating Kyoto University's significant contribution to domestic and international medical science during the 110 years since the founding of the Kyoto Imperial University College of Medicine in 1899. The materials on display include a copy of *Kaitai Shinsyo* (The New Book of Anatomy) which is one of the most valuable books in Japanese medical history, and the doctoral theses of Dr. Hideyo Noguchi, a prominent Japanese bacteriologist.

Please consider visiting the museum during your next visit to Kyoto University. Please note that an advance reservation is required.

Author: **Dr. Nagahiro Minato** Dean, Graduate School of Medicine

www.med.kyoto-u.ac.jp/organization-staff/research/doctoral_course/r-010/

WEB www.shirankai.or.jp/other/topics/stock/whip_rounds2/index.html#t01 (Japanese only)



FRIENDSHIP & COOPERATION

Intercultural Negotiation: Unique Opportunity in Joint Effort with German Program



Bucerius Law School

In negotiation, good relationships breed good outcomes. Negotiating opposite fellow students makes it possible to avoid the challenge of creating good relationships. How can we constructively break out of this problem with a classroom of students? Dealing with new counterparties, particularly when culture, nationality and industry background are disparate, addresses this teaching problem. With this issue in mind, the Will Baber (GSM) developed a negotiation event with Prof. Michael Friedman of the Bucerius /WHU Master of Law and Business (MLB) Program in Hamburg, Germany.

For the third consecutive year students of the Graduate School of Management (GSM) engaged in a negotiation with students in the Bucerius/WHU Master of Law and Business (MLB) Program. The professors jointly designed the negotiation and related assignments. This year, 20 students from Hamburg and 10 from Kyoto participated in the negotiation.

An innovation in 2013 was the addition of a follow-up discussion on Linked In jointly moderated by Baber and Friedman. The discussion group resulted in 14,000 words of comments in about 120 postings on topics from negotiation planning to the challenges of electronic communication.



Baber and Graduate School of Management students (Mie Zheng, Sreehari Jay, Yoav Miro, Koush Singh, Cuc Le Thi)



Prof. Michael Friedman, Guillermo Buganem, and Diego Maldonado of Bucerius MLB

Kyoto GSM student Rachel Sun wrote, “Delivering a sense of respect, trust, and commitment is most difficult, especially where misunderstandings can result due to differences in language and culture.”

MLB student Guillermo Buganem summarized: “The negotiation provided us not only with valuable theoretical knowledge but, most importantly, practical “hands- on” skills that will accompany us in our day-to-day practice long after the program ends.”



Author: **Will Baber** Associate Professor, Graduate School of Management

www.gsm.kyoto-u.ac.jp/ja/faculty-information/business-administration-chairs/194-baber.html

Voices of International Researchers

My Experience of Research and Education in Kyoto University

Japan’s disaster prevention research is the most advanced in the world, and the Disaster Prevention Research Institute (DPRI) of Kyoto University is best known for research on a variety of problems relating to the prevention and reduction of natural disasters from multiple perspectives, encompassing typhoons, floods, landslides, and other disasters. I joined the DPRI in April 2010. As a principal member, I was lucky to join several great international projects: Sustainability/Survivability Science for a Resilient Society Adaptable to Extreme Weather Conditions, Risk Identification and Land-Use Planning for Disaster Mitigation of Landslides and Floods in Croatia, and Development of Landslide Risk Assessment Technology along Transport Arteries in Viet Nam, among others. Through these international projects, I came to realize how advanced the application of high technology in disaster predication and prevention is. By collaborating with many excellent researchers conducting cutting-edge research, I obtained a lot of experience of both education and research on environmental disasters such as water pollution, floods, and landslides. I believe that joining Kyoto University and working with the people here was a great decision, and it will surely advance my career.



Dr. He Bin

Associate Professor, Educational Unit for Adaptation to Extreme Weather Conditions and a Resilient Society

flood.dpri.kyoto-u.ac.jp/member/hebin/bin_he.html

FRIENDSHIP & COOPERATION

International Exchange Course Overseas Study Program



Friendship and academic exchange between KU and Kasetsart University.



Twelve students and two faculty members from Kasetsart University, Bangkok, Thailand, visited Kyoto University for thirteen days from October 14-26, 2013. The visit was part of the international exchange course *Changing Southeast Asia: Environment, Industry and Society*, a joint program between Kasetsart University and Kyoto University's Graduate School of Agriculture. The course was held in corporation with

Kyoto University's Organization for the Promotion of International Relations and Educational Unit for Human Security Development. The students and faculty from Kasetsart University were invited to Kyoto University to participate in classes and field trips. During their stay in Kyoto, they had opportunities to learn about various aspects of traditional Japanese culture, including the *yuzen zome* dyeing technique

and correct way to wear a kimono. They also took field trips to learn about the history, industry, and natural environment of local areas. Kyoto University students who had visited Kasetsart University during previous programs also participated, deepening their friendships with the Kasetsart students. The program has been praised by the staff and students of both universities, and is anticipated to enhance mutual understanding between Kasetsart and Japan.



A group presenting wagashi



At the Agricultural Technology Promotion Center (Ohmihachiman City, Shiga Prefecture)



Visiting Kiyomizu Temple in kimono (Japanese traditional dress)

Author: **Dr. Eiji Nawata**

Professor, Graduate School of Agriculture

WEB kyouindb.iimc.kyoto-u.ac.jp/j/kM91F

Voices of International Researchers

Why I Love Kyoto University

The reason I love working at Kyoto University is simple: the university provides a huge amount of encouragement and support to cutting-edge research. It looks like a hierarchical institution, but in reality, its rather flat organization makes it easy to reach anyone from departmental staff to senior faculty in the President's Office. It allows scholars their independence, but also gives assistance whenever they need it. There is a deep understanding of the significance of diversity and equality, which extends to female researchers and international scholars. There is an excellent body of students, which makes teaching all the more exciting and fun. It is a wonderful place for any serious academic scholar to be!

Dr. Asli M. Colpan

Associate Professor, Graduate School of Management and
The Hakubi Center for Advanced Research, Kyoto University / 2010 Tachibana Award Laureate

WEB www.aslicolpan.com



LARGE-SCALE PROJECTS

Promotion of International Education and Research

Kyoto University actively endeavors to apply the knowledge and technologies generated by its research to educational activities and regional services which will benefit society.

EDUCATION PROJECT

KyotoUx to commence on April 10, 2014.

Interactive online classes and MOOCs from Kyoto, Japan.

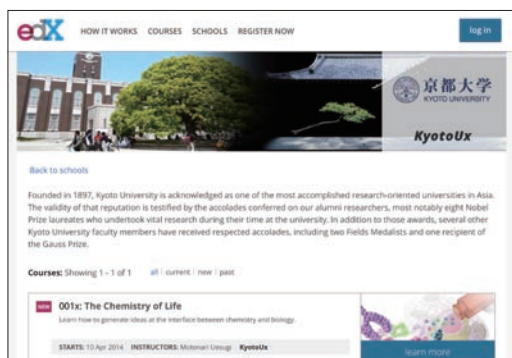

Edx is a non-profit online learning initiative by the leading global institutions of the xConsortium. It offers innovative online courses that implement new teaching methods on an open source platform, including massive open online courses (MOOCs) and blended learning programs that combine interactive online courses at the partner universities and in-person courses at the home university, to any student regardless of age, status, or income level.

Kyoto University has become the first Japanese university to be a part of EdX. Kyoto University launched its OpenCourseWare (OCW) project in 2005 to deliver online courses, and was invited to join EdX because of the outstanding quality and quantity of the materials on offer.

The first edX course by Kyoto University is The Chemistry of Life taught by Prof. Motonari Uesugi of the Institute for Integrated Cell-Material Sciences and Institute for Chemical Research. The course will commence on April 10, 2014. The Chemistry of Life is a general education course for first and second year students at Kyoto University that aims to develop the students' ability to generate new ideas by bringing together knowledge from

the fields of chemistry and biology. The course is open to everyone and may be accessed from the link below. If you are interested, why not give it a try! Registration for a course is still available.

The Chemistry of Life: www.edx.org/course/kyotoux/kyotoux-001x-chemistry-life-858

KyotoUx (external link): www.edx.org/school/kyotoux

OpenCourseWare (OCW): ocw.kyoto-u.ac.jp/

Dr. Naoko Tosa (left)

Professor, Academic Center for Computing and Media Studies

WEB www.tosa.media.kyoto-u.ac.jp www.naokotosa.comc.jp

Dr. Toru Iiyoshi (right)

Director & Professor, Center for the Promotion of Excellence in Higher Education

WEB www.educause.edu/members/toru-iiyoshi

www.youtube.com/watch?v=jzaLqeGwCPE (He is talking about EdX at TEDxYouth@Kyoto)



EDUCATION PROJECT

Kyoto University OpenCourseWare

KU course materials and lectures are available on the web.

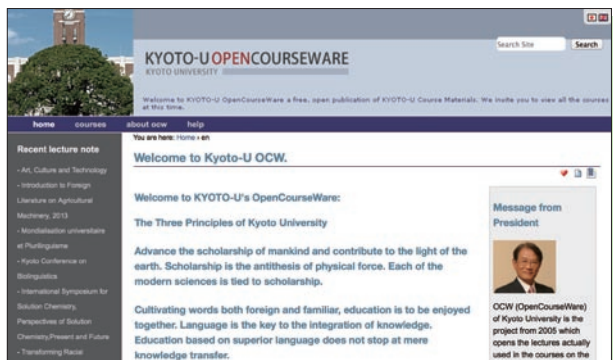

The Kyoto University OpenCourseWare (OCW) project was initiated in 2005 to make selected Kyoto University course materials available on the Web. By publishing the course materials and lectures online the initiative seeks to make the benefits of Kyoto University's education more widely available: not only to the university's students, faculty, and staff, but also to students at other universities, researchers in the academic community, high school students aspiring to enter Kyoto University, and adults seeking further education. The OCW also

plays an important role in increasing the international visibility of Kyoto University and proactively disseminating information on Japanese culture and tradition. With the aim of enhancing human knowledge assets and making them available around the world, the Kyoto University OCW will promote international exchange and expand the scope of university's communication with countries around the world.

WEB ocw.kyoto-u.ac.jp/en

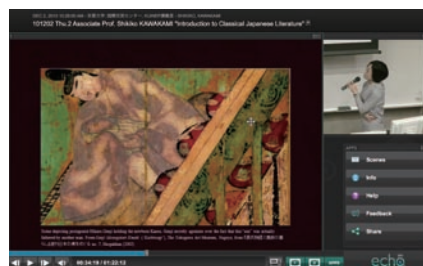

ENHANCEMENT OF RESEARCH UNIVERSITY

Kyoto University Launches New MEXT Research Promotion Program

The Ministry of Education, Culture, Sports, Science and Technology (MEXT) has launched a new program to financially support major Japanese research universities and institutes in further strengthening their promotion of research activities. Kyoto University was selected for the initiative based on its proposal for two types of program—classified as the “Menu A” and “Menu B” programs—which share the common theme of “strengthening research power through trans-boundary approaches.”

The Menu A program consists of plans to recruit university research administrators (URAs), and Kyoto University is aiming to invigorate its URA system by employing twenty new URA staff members in early 2014. The Menu B program comprises various research promotion initiatives such as the Supporting Program for Interaction-based Initiative Team Studies (SPIRITS), the Super John Mung Program, which supports the international development of university faculty and staff, and the Hyakkasōmei Project, which seeks to create a platform for scholars to gather and freely discuss contemporary academic and intellectual issues.

Kyoto University's Research Administration Office (KURA) is in charge of coordinating and managing the program in collaboration with a number of administrative sectors within the university.



WEB research.kyoto-u.ac.jp

CUTTING-EDGE EXPERIMENTAL EQUIPMENT

Facilities for High Quality Research

The Kyoto University's state-of-the-art laboratories and research facilities provide students and researchers with the hands-on practical experience vital to their development as world-class scientists and scholars.

MEDICINAL SCIENCE

The Facility for iPS Cell Therapy

And the iPS Cell Stock Project.

The Facility for iPS Cell Therapy (FiT), a cell processing center at the Center for iPS Cell Research and Application (CiRA), is a core facility to support clinical research through techniques for the generation, expansion and differentiation of induced pluripotent stem cells or iPS cells. Managed by FiT director Dr. Shin Kaneko, an associate professor at CiRA, the facility houses closed and open cell processing rooms, a cell reservation room, a quality control room, a supply room, and a monitoring room. Currently over ten researchers and technicians are working on the production of iPS cell lines in compliance with Good Manufacturing Practice (GMP) standards.

The iPS Cell Stock Project, one of CiRA's major initiatives, takes place at the FiT. The staff generate iPS cells derived from blood cells from healthy HLA-homozygous donors. The iPS cells made at the FiT are rigorously examined for safety and efficacy, and only high quality iPS cells are selected and frozen for stockpiling. The stored iPS cells will be distributed to other research institutes and businesses where they will be differentiated into functional cells such as neurons and heart muscle cells for use in clinical research or cell transplant therapy. CiRA plans to preserve up to ten iPS cell lines to cover approximately thirty to fifty percent of the Japanese population by the end of March 2018. The stock project is part of CiRA's efforts to make iPS cell-based therapy readily available at a reasonable cost.

WEB www.cira.kyoto-u.ac.jp/e/index.html



Cell reservation room



Supply room

CLINICAL MEDICINE

Next-Generation Hybrid Operation Room

Integrated Angiographic Image Supported Operation System.



Recent technological advancements and refinements in endovascular surgery and interventional cardiology have enabled many open surgical procedures to be performed less invasively. Such procedures are called hybrid procedures, and include transcatheter heart valve implantation or endovascular aneurysm repair. Hybrid operating rooms (OR) equipped with angiographic imaging systems are essential for such minimally invasive but complex procedures. Recently, a state-of-the-art hybrid operation room called a next-generation hybrid OR was built at the Kyoto University Hospital. The hybrid OR is an extremely complex working environment that enables a large team of surgeons, interventionalists, nurses, anesthesiologists, and technicians to work seamlessly together. A multi-axis angiographic imaging system based on robotic technology (Artis Zeego, Siemens, Germany), which can be positioned as required, was also installed. The system, which can be controlled with far greater ease and precision than conventional C-arm systems, has three

major advantages: (1) Imaging excellence: benefiting from syngo DynaCT Cardiac acquisition when positioned to the side or laterally to the head, and with the potential for higher speed and accuracy in the rotational run. (2) Enhanced workflow: thanks to its small footprint and multiple park positions, the Artis Zeego is ideally suited for the OR environment. The flexible working height reduces the fatigue associated with long procedures. (3) Economic efficiency: it is possible to perform pre- and post-operative high-end imaging directly in the OR.

In addition to the angiographic imaging system, a surgical navigation system (Brainlab, Germany) was installed. This system ties together the crucial aspects of surgery—from planning and navigation to data management and intra-operative imaging. This integration helps clinicians fully leverage patient data that is continually growing in volume and complexity. Also, this system includes software which helps surgeons make the most of such data during the pre-operative planning. With features such as automatic image fusion and automated workflow options, it enables intelligent planning for a wide variety of procedures in neuro, vascular, trauma, otolaryngologic, and orthopedic surgeries.



Dr. Ryuzo Sakata

Deputy Director of Kyoto University Hospital/Director of Surgery Unit, and Professor and Chairperson, Department of Cardiovascular Surgery in Kyoto University Hospital

WEB www.med.kyoto-u.ac.jp/E/grad_school/introduction/1406/

CIVIL ENGINEERING

The First Multi-Megawatt Floating Offshore Wind Turbines in Japan

Offshore wind energy resources in Japan's EEZ (Exclusive Economic Zone) are now considered to be huge. In order to utilize the large amount of renewable energy located in relatively deep water areas (water depth range: 50-300m), the Ministry of the Environment initiated a demonstration project on floating offshore wind turbines (FOWT) in 2010. Kyoto University is leading this six-year national project as one of its core members.

Two FOWTs have been installed for the project. The first is mounted with a downwind type 100 kW wind turbine, and it is only about half as long as the second FOWT. It is therefore called a half-scale model. The second FOWT is mounted with a downwind type 2 MW wind turbine. This is called a full-scale model. The full-scale model measures 172m from the bottom of its floating foundation to the top of its blades.

The FOWTs consist of a cost-effective PC-steel hybrid spar, and are moored with three anchor chains. On June 11, 2012, the half-scale model was installed at an offshore site near Kabashima Island in Goto City, Nagasaki prefecture as the first grid-connected FOWT in Japan. In September of the same year, the half-scale model was struck by Typhoon Sanba (1216), the most severe tropical typhoon in the world that year. However, the half-scale model survived with no damage, proving the survivability of the spar-type FOWT against typhoons.

After the very successful at-sea experiment of the half-scale model, the full-scale model was installed. The opening ceremony for the first multi-megawatt FOWT in Japan was held on October 28, 2013, and was attended of the Minister of the Environment. This project is anticipated to blaze a trail for the utilization of a huge amount of renewable offshore wind energy resources.



Dr. Tomoaki Utsunomiya

Associate Professor, Department of Civil and Earth Resources Engineering

WEB goto-fowt.go.jp/english/

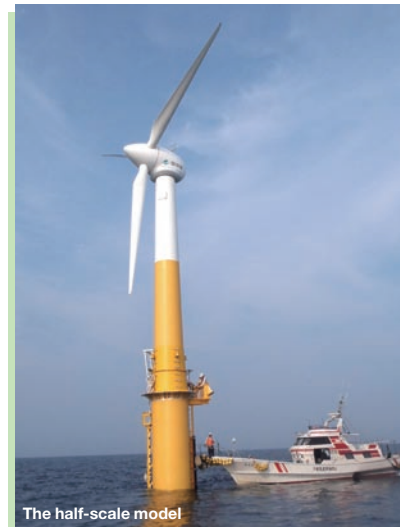

The half-scale model

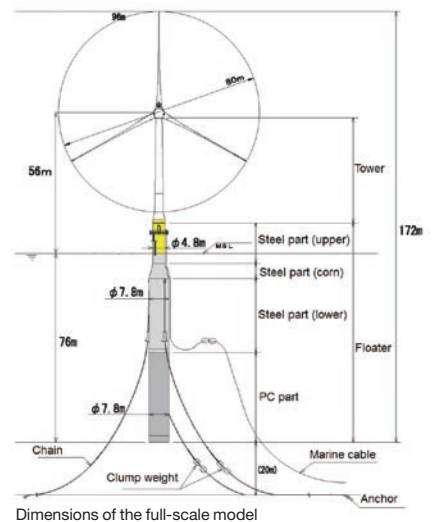

Dimensions of the full-scale model

FOSTERING THE NEXT GENERATION

白眉 — The Hakubi Project

A Unique Opportunity for Outstanding Young Talent

The Hakubi Project was established by Kyoto Univ. in 2009 to foster outstanding young researchers. The program recruits twenty international researchers per year as associate and assistant professors. It gives them a valuable opportunity to devote themselves entirely to their research. The project is open to any researcher in any academic field. **WEB** www.hakubi.kyoto-u.ac.jp/eng

PHIL **Beyond the Phylogenetic Analysis**

Reconstruction of classical Sanskrit treatises on the philosophy of sound.



Extant Sanskrit manuscripts written on palm leaves, tree bark, etc., preserve invaluable insights into the historical evolution of Indian philosophy. However, the accumulated distortion caused by miscopies, alteration, and interpolation in the process of transmission has obscured the concepts and ideas imbedded in the texts themselves. In the work of reconstructing the contents of an original text, the criterion for the adoption of a particular reading is neither majoritarianism nor parsimony. A critical

eye must be directed towards even the unanimous readings common to all testimonies. As a visiting scholar at the Harvard-Yenching Institute, Dr. Taisei Shida, coordinating the collective expertise of his colleagues in Harvard University's Department of South Asian Studies, is editing one chapter of a 10th-century philosophical treatise containing sophisticated argumentation on the nature of sound, language and scripture, topics which constituted the central issues of debate in classical India.

Dr. Taisei Shida

Assistant Professor, The Hakubi Center for Advanced Research / Visiting Scholar, Harvard-Yenching Institute
www.harvard-yenching.org/scholars/shida-taisei



LEGAL-HIS **Justice in Traditional Mongolia**

A study on Mongolian legal history between 1644 and 1949.

This project comprises a monograph on the justice system in Mongolia, including its law and administration, from 1644 to 1949. It is strongly based on the use of local Mongolian legal texts, preserved in archives in Mongolia, Russia, Inner Mongolia and Japan. It employs a multidisciplinary perspective, including legal, historical and anthropological study. As the first comprehensive project in the area of Mongolian legal history, this study will contribute to the understanding of Mongolian legal history and the enrichment of legal history scholarship. It is hoped that it will provide a renewed recognition of the law of nomadic societies worldwide. Dr.

Erdenchuluu is currently an academic visitor at the Centre for Socio-Legal Studies, University of Oxford.

Dr. Erdenchuluu Khohchahar

Assistant Professor, The Hakubi Center for Advanced Research / Visiting Scholar, University of Oxford
www.hakubi.kyoto-u.ac.jp/eng/02_mem/h25/erdenchuluu.html



Mongolian judicial records from the 1760s



POL-SCI **The Right Price for Order**

Prison Policies in Japan.

Japan’s prison system is renowned for its safety and order. There has not been a single prison riot in post-war Japan, and the assault and escape figures lower than elsewhere. Maintaining such a high degree of safety and order is something that the Japanese Justice Ministry is extremely proud of. And why not? Surely a well-ordered prison benefits everyone in society, including prisoners themselves. Nonetheless, international instruments to which Japan is a party hold that the humanity of a prisoner commands rights other than the right to security. The aim of Dr. Silvia Croydon’s research is to empirically determine whose interpretation of prisoners’ rights the existing Japanese prison policies, which have resulted in such a high degree of order, represent. This work should be of benefit to not only scholars of the Japanese criminal justice,

but also to those foreign policymakers who are increasingly looking towards Japan for lessons on how to improve their own prisons.



Dr. Silvia Croydon

Assistant professor, the Hakubi Centre for Advanced Research/Graduate School of Law (currently a visiting scholar at the Faculty of Asian and Middle Eastern Studies, University of Cambridge, U.K.)

www.hakubi.kyoto-u.ac.jp/eng/02_mem/h24/croydon.html

	ASSAULT ON STAFF	ASSAULT ON INMATES	FIRE	ESCAPE	SUICIDE
2005	2	15	0	1	15
2006	4	25	1	0	18
2007	4	12	0	1	21
2008	0	7	1	0	25
2009	0	7	0	0	15

Incidents in Japanese Prisons

To put these figures into perspective, the U.K., which has a prison population of a similar size to that of Japan (of approximately 60,000-70,000 inmates), recorded by contrast that a ‘serious assault’ occurred for every 1.57 inmates in 2004-5, which corresponds to over 40,000 such incidents.

[Source: *MOJ pamphlet, Penal Institutions in Japan, 2011*]

PHYS **Homework from Einstein**

Can we resolve the contradictions between quantum mechanics and general relativity?

In the early 20th century, Einstein’s two great ideas—quantum mechanics and general relativity—completely changed previously held notions about nature. Those theories are not just academic subjects, they are the basis of many common technologies, such as mobile phones and GPS devices. Fascinating phenomena can be predicted by combining the two theories. For example, Dr. Stephen Hawking predicted that a black hole, from which “even light cannot escape,” actually emits particles and disappears due to the quantum effect. At the same time, we often encounter serious contradictions between the two theories. At the Stanford Institute for Theoretical Physics, Prof. Masanori Hanada is trying to establish superstring theory as a consistent description of the quantum version of general relativity.

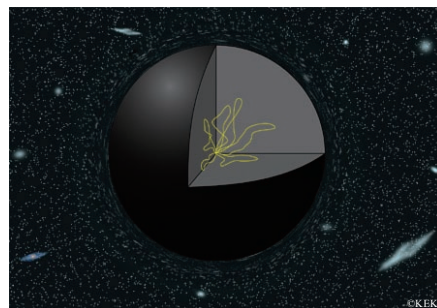

In superstring theory, black hole is described as a condensation of vibrating strings.



Dr. Masanori Hanada

Associate Professor, the Hakubi Centre for Advanced Research/ Visiting Scholar, Stanford Institute for Theoretical Physics

www.hakubi.kyoto-u.ac.jp/eng/02_mem/h25/hanada.html

What’s in a Name?

The term hakubi (白眉), literally means ‘white eyebrows’ in Japanese (白 : white, 眉 : eyebrows). The word originates from a Three Kingdoms era (220-280 AD) Chinese legend: “Three kingdoms saga (三国志)”. According to the legend, one of the kingdoms, called Shu (蜀), was home to five brothers with extraordinary talents. The fourth brother, 馬良季常 (Baryo Kijō), who was particularly outstanding, had white hairs in his eyebrows, and so the term hakubi has come to refer to particularly talented individuals.



FOSTERING THE NEXT GENERATION

The John Mung Program

Opportunities to Explore Global Frontiers

Kyoto University launched the John Mung Program in 2012, as a project to support mid- and long-term research by junior faculty members at leading academic institutions overseas.

MED Imperial College National Health Trust, England

Learning how the Antimicrobial Stewardship Program has been implemented there.



Antimicrobial resistance is an important patient safety and public health issue. Controlling antimicrobial resistance requires a multifaceted approach. The Antimicrobial Stewardship Program (ASP) seeks to improve antimicrobial prescribing and control antimicrobial resistance. In England, an active ASP has been implemented for a considerable time, and reduction of nosocomial infections has been achieved through stringent and effective infection control practices. The aim of my visit was to learn how the ASP has been implemented at the Imperial College National Health Trust, and to establish a research network with one of the leading research teams in Europe. I am confident that the human network, knowledge, and skills I gained will be beneficial in my future research.



Dr. Miki Nagao *MD, PhD, Kyoto University Graduate School of Medicine*
kyouindb.iimc.kyoto-u.ac.jp/e/mS6HT

MATH Bielefeld University, Germany

Studying the analysis and geometry of Laplacian on closed Riemannian manifolds.



During my stay at Bielefeld University, I studied the analysis and geometry of Laplacian on closed Riemannian manifolds. I visited Prof. Alexander Grygor'yan's office several times to discuss my above studies. During the visit, I also had opportunities to communicate with researchers from different areas of mathematics. My diverse discussions with them brought great surprises and gave me much inspiration for my research. I believe that these experiences will be invaluable throughout my research life.

Dr. Kei Funano *Graduate school of Science*
kyouindb.iimc.kyoto-u.ac.jp/e/xH5hI

The John Mung Advanced Program



Kyoto University launched the John Mung Program (Kyoto University Young Scholars Overseas Visit Program) in 2012, as a project to support mid- and long-term research by junior faculty at overseas organizations. The objective of the program is to encourage young scholars to develop academic networks and promote collaborative research projects. This in turn will build a foundation to advance academic exchange, internationalize research activities, and facilitate the

expansion of external funding opportunities.

The program supports young scholars in two different ways. The Young Scholars Overseas Visit Program supports individual scholars by providing funds for their travel, living, and research expenses. The Program for Scholars' Home Laboratories provides funding to departments, laboratories, and other academic units to compensate for the absence of young scholars who are stationed abroad for over six months. Grants can be used to cover personnel and operational expenses incurred during the period of their absence.

In 2013, the program was revised as the John Mung



MICRO-ENG **Stanford University, USA**

Working on microsystems for on-chip chemical analysis.



I joined Professor Santiago's group at Stanford University. The group is actively working on the development of microsystems for on-chip chemical analysis, drug delivery, and sample preparation methods. My current research project is the extraction of ribonucleic acid (RNA) and deoxyribonucleic acid (DNA) from a single cell using electric cell lysis and isotachopheresis. I have been working with excellent colleagues in a fulfilling research environment. I would like to express my sincere gratitude to all those involved for providing me with this opportunity to do research at Stanford University.



Dr. Hirofumi Shintaku

Visiting Scholar, Department of Mechanical Engineering, Stanford University / Assistant Professor, Graduate School of Engineering, Kyoto University
kyouindb.iimc.kyoto-u.ac.jp/e/gW0jR

POLY-CHEM **University of Washington, USA**

Studying cAFM and pcAFM.

Thanks to the John Mung Program, I had the opportunity to study conductive atomic force microscopy (cAFM) and photoconductive atomic force microscopy (pcAFM) as applied to polymer-based organic solar cells at the University of Washington in the United States. The AFM techniques are state-of-the-art and powerful tools which enable us to discuss the mechanism of photovoltaics at the molecular level. I was engaged in full-time research under the guidance of Prof. David S. Ginger, and worked as a postdoctoral research fellow in his laboratory. During my stay, I enjoyed mastering the skills of AFM techniques and discussing my



research findings there with students, postdocs, and Prof. Ginger. Our collaborative research is continuing even since I returned to Japan. I believe this valuable experience will develop my research much further.

Dr. Hiroaki Benten *Graduate School of Engineering*

www.photo.polym.kyoto-u.ac.jp

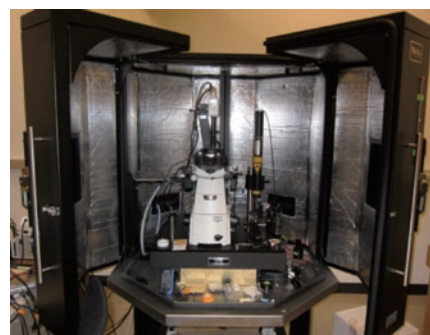

pcAFM

Advanced Program. The advanced program offers opportunities for overseas experience to a wider range of faculty members by expanding its scope of eligibility and offering more varied funding schemes. The advanced program allows scholars to apply as a team, in collaboration with other young scholars or students. This enables applicants to expand the scale of their projects. Through this program Kyoto University aims to cultivate an increased number of internationally-minded, leading scholars.

WEB www.kyoto-u.ac.jp/ja/research/young/support/john_man/

	John Mung Program	John Mung Advanced Program
Category	Faculty Member	Faculty Member Non-tenure track scholar
Age	Under 40	Under 50
Period	3-12 months	3-24 months (1-3 months possible depending on a reason)
Unit	Individual	Individual, Team (Students can be included in a team)
Program for Scholar's Home Laboratories	Approx. \$2,000/month/person	Approx. \$3,000/month/person

Cutting-Edge Research in Kyoto University

Kyoto University is known for the quality and diversity of its research. Each issue of Research Activities can only highlight a small selection of those endeavors, but we hope to convey an impression of the university's rich academic milieu.

MEDIA-ART The Sound of Ikebana: Four Seasons

Images of splashing liquids created from sound vibrations.

A projection mapping of Prof. Naoko Tosa's video work was performed on January 17-19 as part of an event to promote the Cool Japan initiative supported by Japan's Ministry of Economy, Trade and Industry (METI) and Ministry of Internal Affairs and Communications (MIC). Prof. Tosa's new video work "The Sound of Ikebana: Four Seasons" was projected on the exterior of the ArtScience Museum at Marina Bay Sands, which is built in the shape of a lotus flower. Singapore Art Week 2014 was held on January 13-19 in Singapore, and several art festivals, including Art Stage Singapore, were held in parallel to bring together galleries and collectors from around the world.

Prof. Tosa's program was presented as part of the festivities, and was supported by METI, the Singapore Tourism Board, the Urban Redevelopment Authority, and other organizations. The Sound of Ikebana is a series of videos shot with a high-speed camera that showcases vibrant images of splashing liquids created from low-frequency sound vibrations. The video installation artistically presents the movement of the splashing liquids as arranged flowers. Through the successive formation of colorful arranged flowers, the video work provided an extraordinary experience of the four seasons of Japan to the viewers in Singapore, a country which doesn't have such distinct seasons.



Dr. Naoko Tosa *Professor, Academic Center for Computing and Media Studies*
www.naokotosa.com

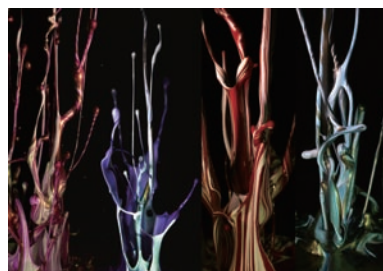

Spring, Summer, Autumn, Winter



Projection mapping "Sound of Ikebana: Four Seasons"

WEB youtube.com/watch?v=3oO3lohMX7k
youtube.com/watch?v=7kqUpkyetOW

INFO-ENG Encouraging Spontaneous Safe Driving Behavior

Driver-assistance system with consideration for drivers' behavioral adaptation and motivation.



Driver-assistance systems, such as an emergency brake assist, have become widely used in many passenger vehicles. Meanwhile, a psychological theory known as risk homeostasis theory asserts that drivers' risk compensation behavior will reduce the long-term effectiveness of such systems. Dr. Toshihiro Hiraoka is conducting research on driver-assistance systems that provide drivers with appropriate information and encourage them to change their driving behavior for the better. He has developed an ecological interface for the driver-assistance system based on motivation psychology and gamification, and has performed driving simulator experiments to evaluate the effectiveness of the proposed system.

Dr. Toshihiro Hiraoka

Assistant Professor, Graduate School of Informatics
www.symbal.sys.i.kyoto-u.ac.jp/~hiraoka/



PSYCHOL The Way People Understand Another People's Mind

Role-play Experience Facilitates Mindreading Skills.

It is often difficult to understand the mind of people who possess different cognitive abilities or traits. One of the effective ways to understand their mind is to have a role play experience. Furumi and Koyasu's (2013, PLoS ONE) experimental study has shown that a role-play experience facilitates reading of the mind of people with restricted color vision. In the study, forty students were given a communication task. No-role-play participants made significantly more errors in the restricted color vision condition than in the normal color vision condition, whereas among role-play participants, there was no difference in errors between conditions.

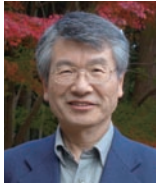

Dr. Masuo Koyasu

Professor, Graduate School of Education

www.educ.kyoto-u.ac.jp/cogpsy/member/koyasu.html

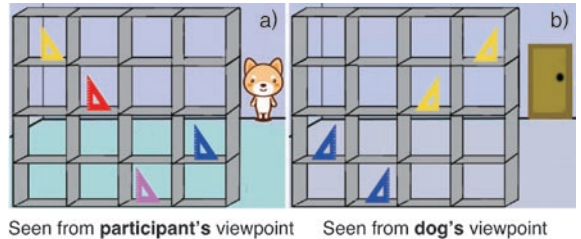

Seen from participant's viewpoint Seen from dog's viewpoint

MED-BIOL Kidney Tissue Regenerated from iPS Cells

iPS cells can serve as a promising source of renal cells and tissues for regenerative medicine.

Kidney diseases cause both medical and economical problems all over the world. Since there are no radical therapies for kidney diseases besides renal transplantation, the development of regenerative medicine strategies using induced pluripotent stem (iPS) cells is required. However, the methods to generate renal cells or tissues from iPS cells have not yet been established. Dr. Kenji Osafune's group recently succeeded in the highly efficient induction of human iPS cells into intermediate mesoderm, an embryonic tissue that gives rise to most cells constituting adult kidneys. It was also demonstrated that human mesoderm cells have the developmental potential to further differentiate into adult renal cell types and form three-dimensional renal tubular structures in vitro. The research group is currently aiming to generate metabolically or physiologically functional renal tissues from human iPS cells to develop regenerative treatments for kidney diseases.

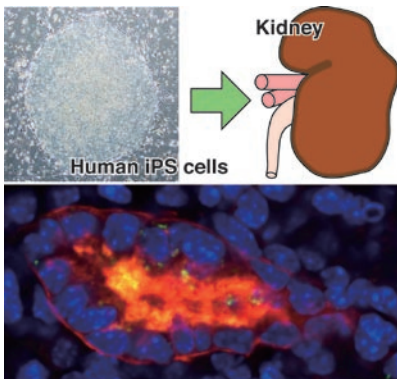

Kidney tissue regenerated from iPS cells
(S. Mae et al., Nat. Commun., 2013)

Dr. Kenji Osafune
Associate professor, Center for iPS Cell Research and Application (CiRA)
www.cira.kyoto-u.ac.jp/j/research/osafune_summary.html



EVOL-BIOL Web of Life

Ecology and genome biology are uncovering the complex networks of species in ecosystems.

Organisms do not live alone. Like individuals in human society, all species in ecosystems interact with other species, forming one of the most complex systems found in nature. By integrating genome biological technologies with theoretical ecology, Prof. Hirokazu Toju and his colleagues are investigating the hyper-complex networks of interactions between plants and their fungal symbionts in roots. As those belowground fungi are essential for the survival and growth of plants in forests, grasslands, and farmlands, their findings provide novel empirical and theoretical bases for ecosystem restoration and next-generation agriculture that fully utilizes the beneficial functions of diverse soil microbes.



Dr. Hirokazu Toju

Assistant Professor, Graduate School of Human and Environmental Studies
sites.google.com/site/toju/

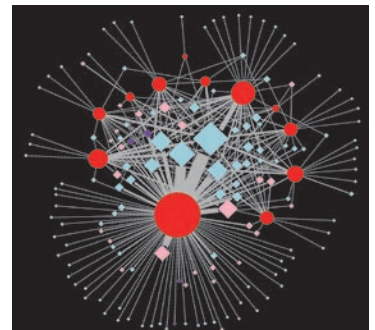

Network representing interactions between plant species (circles) and their root-associated fungal symbionts (diamonds) on Mt. Yoshida, Kyoto, Japan.

PLANT-PATH Why Are Plants So Healthy around a Lot of Small Enemies?

Molecular dissection of nonhost plant resistance against fungal pathogens.

Fungi are the main plant pathogens and cause approximately 70% of all known plant diseases. However, each fungal pathogen generally exhibits a limited host range, because plants exhibit durable resistance, called nonhost resistance, toward fungal pathogens to which they are not adapted. Dr. Yoshitaka Takano and his colleagues' studies on the nonhost resistance of the model plant *Arabidopsis thaliana* revealed that this durable resistance is guaranteed by a two-layered defense mechanism. The first layer of defense works to prevent fungal pathogens from entering the plant, and entails the activation of multiple antifungal responses, including antifungal peptide production. The second layer of defense works when the pathogen successfully enters the plant and involves antifungal metabolite synthesis and the subsequent execution of programmed plant cell death around entry sites. This study begins to explain why plants are so healthy in the presence of a lot of potential fungal pathogens.



Dr. Yoshitaka Takano

Associate Professor, Graduate School of Agriculture
www.plant-pathology.kais.kyoto-u.ac.jp/

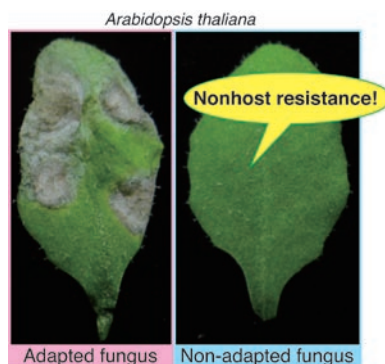

PSYCHOL Human Memory and Brains

Viewing how memory functions are represented in the human brain.



Memory is one of the important cognitive functions in humans. Traditionally, human memory research has been performed in the field of experimental psychology, but recent advances in functional neuroimaging techniques, such as functional magnetic resonance imaging (fMRI) have enabled scientists to view how memory functions are represented in the human brain. Using the fMRI, Prof. Takashi Tsukiura and his colleagues are trying to disentangle the mysterious link between human memory and the brain. Their interests of research are to study how episodic memories are modulated by other psychological processes, such as emotion, reward, etc., and how memories are affected by aging. They believe that their research could lead to understanding human memory systems from a neuroscientific basis, and could contribute to supporting elderly people with age-dependent cognitive decline.

Dr. Takashi Tsukiura

Associate Professor, Graduate School of Human and Environmental Studies
www.h.kyoto-u.ac.jp/staff/131_tsukiura_t_0_e.html



MED-BIOL Why Don't We Create a New Neural Network?

Transplantation of iPS cell-derived dopaminergic neurons to treat Parkinson's disease.

Parkinson's disease (PD) is a neurodegenerative disease characterized by a progressive loss of midbrain dopaminergic (DA) neurons, which causes motor complication such as tremor, rigidity and dyskinesia. Although pharmacological treatment has proven effective at the initial stage, the fundamental problem of PD is a loss of DA neurons. Dr. Jun Takahashi and his colleagues have been developing a cell transplantation therapy by using iPS cells. They have already succeeded in improving the symptoms in monkey PD models. Dr. Takahashi explains that "the main purpose of surgical treatment is to remove lesions, but we aim to create a new neural network in the brain."



Dr. Jun Takahashi Professor, Center for iPS Cell Research and Application

www.cira.kyoto-u.ac.jp/j/research/takahashi_summary.html

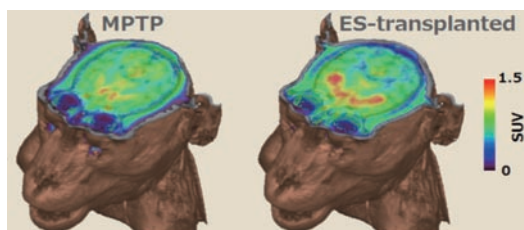

MED-BIOL First Step to New Cancer Treatment

Structure of new protein linked to cancer revealed.

Some proteins, including Ras, are controlling signals for cell growth and division. Overactivation of the signaling can lead to cancer. Mutations that permanently activate Ras are found in up to 90% in pancreatic cancer. To become active, Ras needs to be processed by a protein called Rce1, which is an intramembrane proteinase. Membrane protein crystallization, essential for structure determination, is still a major challenge. Prof. Iwata and his colleagues applied their unique technique of using an antibody fragment to crystallise Rce1, and succeeded in determining the structure by X-ray crystallography. The structure will provide a boost to the design of new cancer drugs which inhibit Rce1 activity.



Dr. So Iwata *Professor, Graduate School of Medicine*
cell.mfour.med.kyoto-u.ac.jp/en/index.html

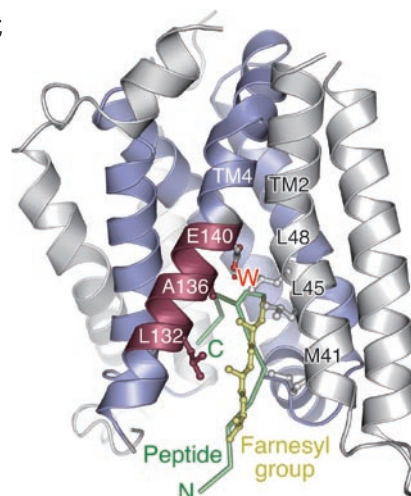

ELECTROCHEM High-Energy-Density Rechargeable Battery

Magnesium rechargeable battery using earth-abundant and non-toxic elements.

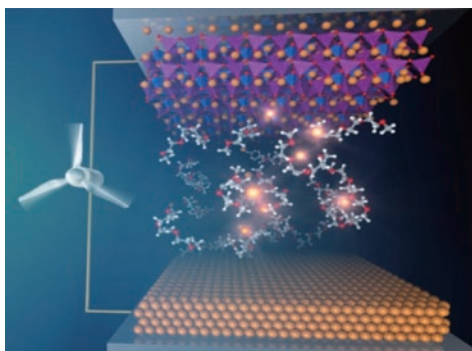

Magnesium rechargeable batteries, in which magnesium ions replace lithium ions as the charge carrier in lithium ion batteries, are expected to be high-energy density. Prof. Yoshiharu Uchimoto and Prof. Yuki Oriksa have developed two distinct approaches to both cathodes and electrolytes for the practical application of magnesium rechargeable batteries. For cathodes, using poly-anion compounds demonstrates a high reversible capacity exceeding 300 mAh g^{-1} . The novel battery system achieves a low cost, practical high-energy-density rechargeable battery free from corrosion and safety problems, and is expected to be a viable alternative to large-scale energy storage devices in smart grid communities and electric vehicles.

Dr. Yoshiharu Uchimoto (left)

Professor, Graduate School of Human and Environmental Studies

Dr. Yuki Oriksa (right)

Assistant Professor, Graduate School of Human and Environmental Studies
www.uchimoto.jinkan.kyoto-u.ac.jp/



EVOL-BIOL Twisting Evolutionary Puzzle Solved

“Right-handed” snakes drive the evolution of “left-handed” snails.

Right-handed (clockwise coiling) and left-handed (counter-clockwise coiling) snails can rarely mate with each other due to mismatched genitals. For this reason, chirality is generally monomorphic within a species, and is usually right-handed. However, some snail taxa are left-handed. This fact indicates that they have evolved from right-handed ancestors despite the mating disadvantage. Recently, Dr. Masaki Hosono found that some snakes are specialized predators of right-handed snails (the majority), and that the “right-handed” snakes were responsible for the origin of left-handed snail taxa. Dr. Hosono's study illustrates that a single gene for reproductive incompatibility can have a major positive effect on anti-predator adaptation.



Dr. Masaki Hosono

Assistant Professor / The Hakubi Center for Advanced Research
sites.google.com/site/hosono0822/



RESEARCH OUTPUT

Kyoto University Merchandise?! Another Use for Research Results

When you visit Kyoto University, why don't you buy some merchandise based on the results of research undertaken at the university? Merchandise is available from the gift shop located in the Clock Tower Centennial Hall, the "Musep" gift shop in the Kyoto University Museum, and selected co-op shops on campus.

WEB www.s-coop.net/goods/ (Kyoto University Gift Shop, Japanese Only)
musep.jimdo.com (Muzep, Japanese Only)

GEOMETRY

Imaginary Cubes

Imaginary cubes are objects with square projections on three orthogonal planes that look like cubes. Dr. Hideki Tsuiki and his colleagues discovered imaginary cubes with unusual properties, and used them as the basis for the design of two types of puzzle.



The objective of the wooden puzzles is to put nine imaginary cube pieces into a box, and the objective of the paper puzzles is to assemble imaginary cube objects which are composed of nine cubes. As well as being fun, Dr. Tsuiki hopes that people will be inspired by the mathematical beauty which exists behind the puzzles.

Dr. Hideki Tsuiki

Professor, Graduate School of
Human and Environmental Studies
www.i.h.kyoto-u.ac.jp/~tsuiki

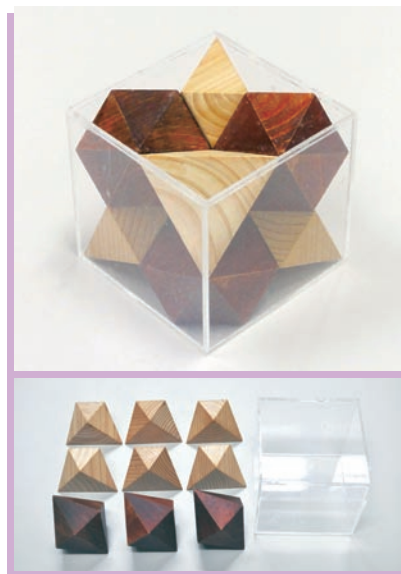

CHEMISTRY

21st Century Periodic Table: The Elementouch[®]

The 3D layout of element symbols resolves some shortcomings of the widely used current table.

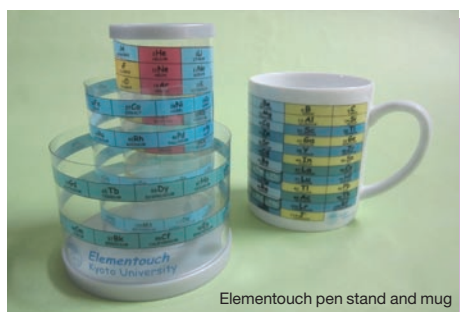

It is wonderful that the atomic building blocks of all matter, the elements, can be arranged in one table: the periodic table of the elements. The long-period periodic table currently used worldwide was invented in 1905 by Alfred Werner, who later won the Nobel Prize in Chemistry. Prof. Yoshiteru Maeno has invented a new periodic table with a three-dimensional layout called the Elementouch[®], which resolves some shortcomings of Werner's table. Firstly, all of the element symbols are arranged continuously without any gap. Secondly, elements with similar ionic properties are grouped together in the same columns.



In addition, when viewed from the top, the Elementouch depicts different atomic orbitals around the nucleus. If Werner's periodic table is a "world map" of the elements, the Elementouch could be described as a "globe."

The Elementouch has been used at a variety of science education events. It also features on several Kyoto University products, such as a pen stand, mug, t-shirt and towel, which are available from Kyoto University stores as well as various science museum shops.

Detailed description: www.ss.scphys.kyoto-u.ac.jp/elementouch/index.html

YouTube site: www.youtube.com/watch?v=Hsll4KhPIKM

KU Co-op HP: rept.kyoto-bauc.or.jp/goods/kyodai_goods/indicate.php?mode=top&category=1

Dr. Yoshiteru Maeno *Professor, Graduate School of Science*

www.ss.scphys.kyoto-u.ac.jp/person/maeno/index_e.html

ALGEBRA

Prime Number Ruler

The Prime Number Ruler is a popular item that has been sold at Kyoto University CO-OP stores since May 2013. In a sense, the ruler is difficult to use because only prime numbers are marked on it. However, this novelty appeals to a lot of people, so the CO-OP has to limit sales of the ruler to one per customer. The original idea was developed in a class of the Kyoto University Summer Design School 2012. The class was operated by the FUBEN-EKI Institute, an organization run by Kyoto University researchers. The institute's name stands for "FURTHER BENEfit of a Kind of Inconvenience." The price of the ruler is also a prime number. How much will it be after the sales tax goes up?



Dr. Hiroshi Kawakami *Associate Professor, Graduate School of Informatics*

www.symlab.sys.i.kyoto-u.ac.jp/~kawakami/index.html

DISASTER PREVENTION

Gaming & Simulation for Disaster Damage Reduction

Developing new disaster education materials: "Crossroad" & "Individual Drill".



Visualization of evacuation procedure, red line indicating the path taken to reach the current location, and dark blue zone indicating the area inundated by simulated tsunami.

The disaster simulation game "Crossroad" is a group game which aims to have players think about disasters not as others' business, but as their own business, and exchange their opinions with others. In this game, each player answers "yes" or "no" to questions with two choices which deal with common dilemmas in disasters. "Individual drills" are tsunami evacuation drills that are carried out by each person individually. The evacuation procedure is captured on video by local school children, the results are analyzed, and messages from the children are passed to the drill participants. Furthermore, the evacuation procedure is visualized through computer graphics that superimpose a simulation of tsunami inundation.

Dr. Katsuya Yamori

Professor, Disaster Prevention Research Institute

www.drs.dpri.kyoto-u.ac.jp/staff/yamori/ www.drs.dpri.kyoto-u.ac.jp/gsp/

Author Index

Baber, William	www.gsm.kyoto-u.ac.jp/ja/faculty-information/business-administration-chairs/194-baber.html	16
Benten, Hiroaki (辨天 宏明)	www.photo.polym.kyoto-u.ac.jp	25
Bin, He (賀 斌)	flood.dpri.kyoto-u.ac.jp/member/hebin/bin_he.html	16
Colpan, Asli	www.aslicolpan.com	17
Croydon, Silvia	www.hakubi.kyoto-u.ac.jp/eng/02_mem/h24/croydon.html	23
Erdenchuluu, Khohchahar (額定 其勞)	www.hakubi.kyoto-u.ac.jp/eng/02_mem/h25/erdenchuluu.html	22
Funano, Kei (船野 敬)	kyouindb.iimc.kyoto-u.ac.jp/e/xH5hI	24
Hanada, Masanori (花田 政範)	www.hakubi.kyoto-u.ac.jp/eng/02_mem/h25/hanada.html	23
Hiraoka, Toshihiro (平岡 敏洋)	www.symbalab.sys.i.kyoto-u.ac.jp/~hiraoka/	26
Hoso, Masaki (細 将貴)	sites.google.com/site/hoso0822/	29
Iiyoshi, Toru (飯吉 透)	www.educause.edu/members/toru-iiyoshi www.youtube.com/watch?v=jzaLqGwCPE	18
Iwata, So (岩田 想)	cell.mfour.med.kyoto-u.ac.jp/en/index.html	29
Kawakami, Hiroshi (川上 浩司)	www.symbalab.sys.i.kyoto-u.ac.jp/~kawakami/index.html	31
Kobayahsi, Kiyoshi (小林 潔司)	kyouindb.iimc.kyoto-u.ac.jp/e/hR7IU	7
Koyasu, Masuo (子安 増生)	www.educ.kyoto-u.ac.jp/cogpsy/member/koyasu.html	27
Maeno, Yoshiteru (前野 悦輝)	www.ss.scphys.kyoto-u.ac.jp/person/maeno/index_e.html	31
Minato, Nagahiro (湊 長博)	www.med.kyoto-u.ac.jp/organization-staff/research/doctoral_course/r-010/ www.shirankai.or.jp/other/topics/stock/whip-rounds2/index.html#t01	15
Motokawa, Masaharu (本川 雅治)	www.museum.kyoto-u.ac.jp/aa/index_en.html	14
Nagao, Miki (長尾 美紀)	kyouindb.iimc.kyoto-u.ac.jp/e/mS6hT	24
Nawata, Eiji (縄田 栄治)	kyouindb.iimc.kyoto-u.ac.jp/j/kM9lF	17
Orikasa, Yuki (折笠 有基)	www.uchimoto.jinkan.kyoto-u.ac.jp/	29
Osafune, Kenji (長船 健二)	www.cira.kyoto-u.ac.jp/e/research/osafune_summary.html	27
Sakata, Ryuzo (坂田 隆造)	www.med.kyoto-u.ac.jp/E/grad_school/introduction/1406/	21
Shida, Taisei (志田 泰盛)	www.harvard-yenching.org/scholars/shida-taisei	22
Shintaku, Hirofumi (新宅 博文)	kyouindb.iimc.kyoto-u.ac.jp/e/gW0jR	25
Toju, Hirokazu (東樹 宏和)	sites.google.com/site/toju/	27
Takahashi, Jun (高橋 淳)	www.cira.kyoto-u.ac.jp/e/research/takahashi_summary.html	28
Takano, Yoshitaka (高野 義孝)	www.plant-pathology.kais.kyoto-u.ac.jp/	28
Tosa, Naoko (土佐 尚子)	www.tosa.media.kyoto-u.ac.jp www.naokotosa.com	18, 26
Tsuiki, Hideki (立木 秀樹)	www.i.h.kyoto-u.ac.jp/~tsuiki	30
Tsukiura, Takashi (月浦 崇)	www.h.kyoto-u.ac.jp/staff/131_tsukiura_t_0_e.html	28
Uchimoto, Yoshiharu (内本 喜晴)	www.uchimoto.jinkan.kyoto-u.ac.jp/	29
Utsunomiya, Tomoaki (宇都宮 智昭)	goto-fowt.go.jp/english/	21
Yamagiwa, Juichi (山極 寿一)	jinrui.zool.kyoto-u.ac.jp/others/WelcomeE.html	4
Yamori, Katsuya (矢守 克也)	www.drs.dpri.kyoto-u.ac.jp/staff/yamori/ www.drs.dpri.kyoto-u.ac.jp/gsp/	31

This information is also available online. **WEB** www.kyoto-u.ac.jp/ja/issue/research_activities



Map and Access

More information on how to visit Kyoto University can be found at the following WEB site;
www.kyoto-u.ac.jp/en/access

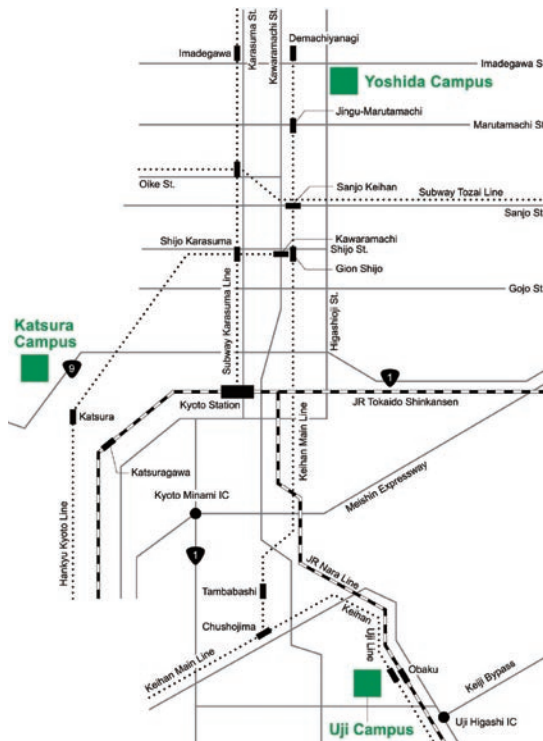

General Contact Information

Kyoto University

Yoshida-Honmachi, Sakyo-ku, Kyoto, JAPAN 606-8501

www.kyoto-u.ac.jp

Researchers:

International Affairs Division

Tel: +81-75-753-2047

Fax: +81-75-753-2042

E-mail: koryu52@mail.adm.kyoto-u.ac.jp (visitation support)

research_promotion@mail2.adm.kyoto-u.ac.jp (research collaboration support)

Businesses:

Office of Society-Academia Collaboration for Innovation

Tel: +81-75-753-5534

Fax: +81-75-753-5538

E-mail: info@saci.kyoto-u.ac.jp

Students:

Foreign Student Division

Tel: +81-75-753-2543

Fax: +81-75-753-2562

E-mail: ryugak78@mail.adm.kyoto-u.ac.jp

For inquiries regarding this publication:

Research and International Affairs Department

E-mail: research_activities@mail2.adm.kyoto-u.ac.jp

This publication is available online at;

www.kyoto-u.ac.jp/en/issue/research_activities

 [research activities kyoto univ](http://www.kyoto-u.ac.jp/en/issue/research_activities)



